

Color Notes

COLOR INDEX

- PLOT BOUNDARY
ABUTTING ROAD
PROPOSED WORK (COVERAGE AREA)
EXISTING (To be retained)
EXISTING (To be demolished)

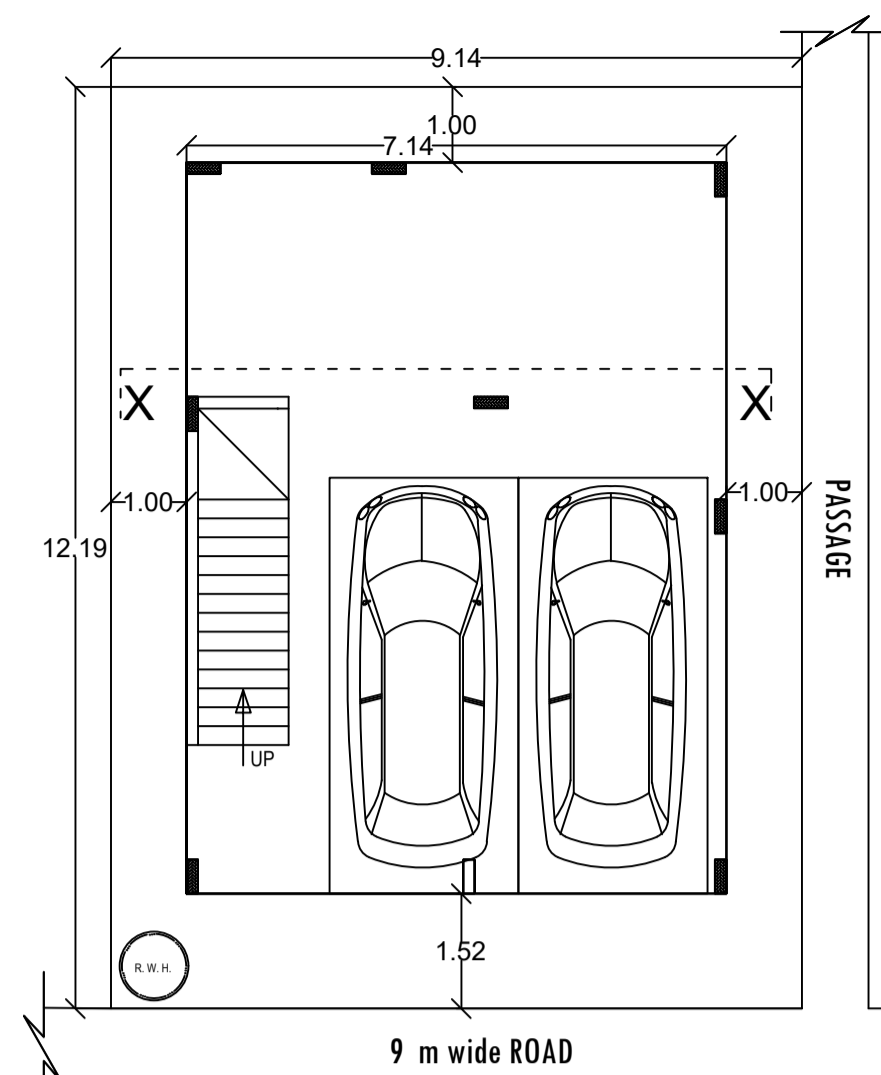

STILT FLOOR PLAN

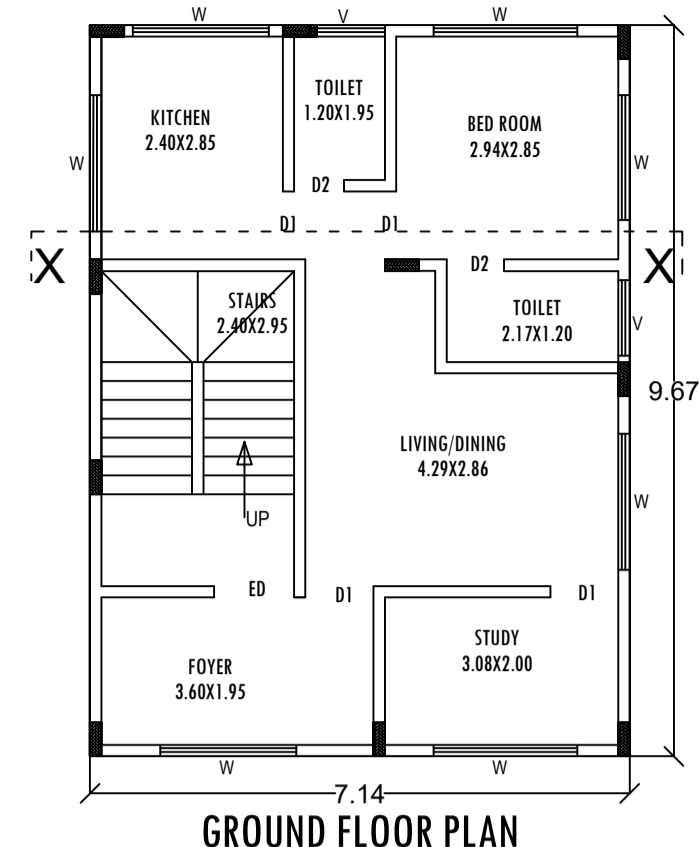

GROUND FLOOR PLAN

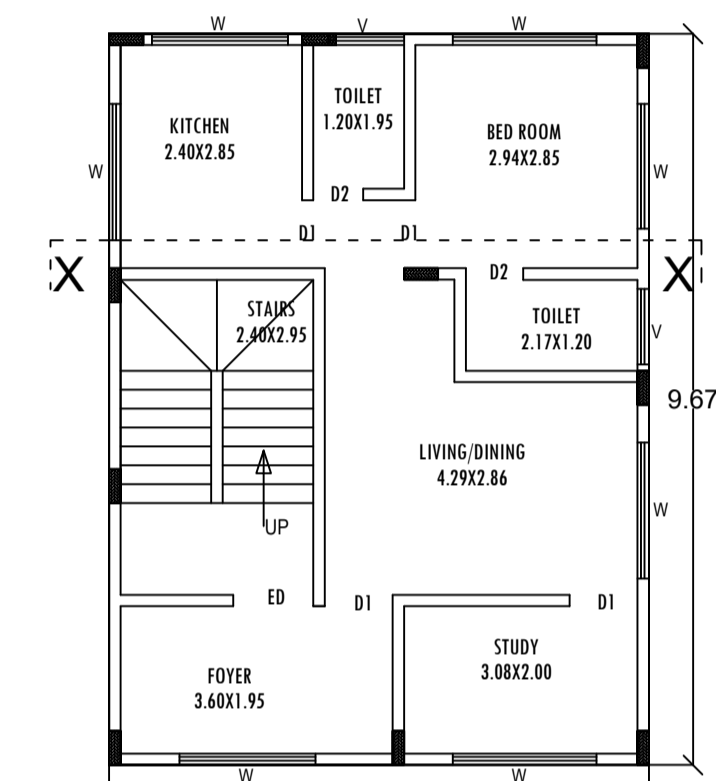

TYPICAL 1st & 2nd FLOOR PLAN

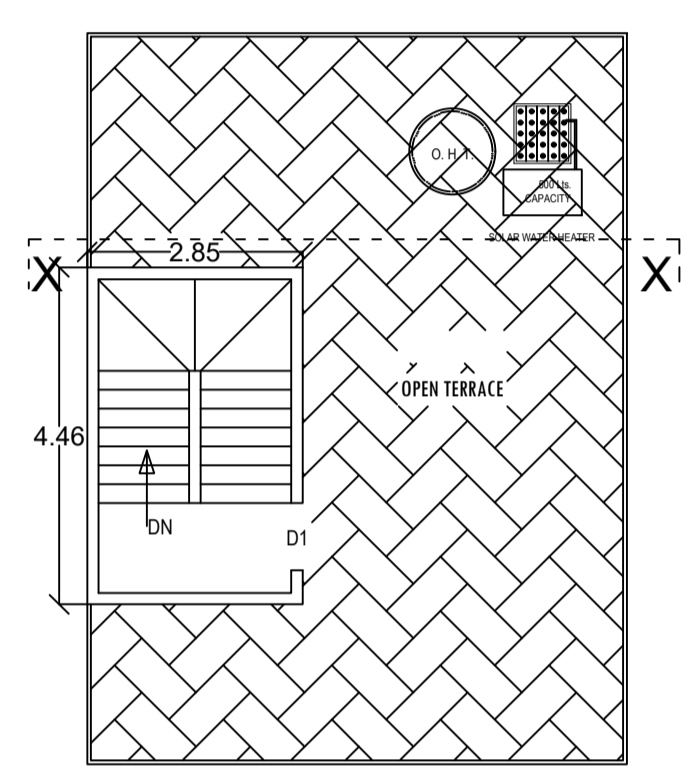

TERRACE FLOOR PLAN

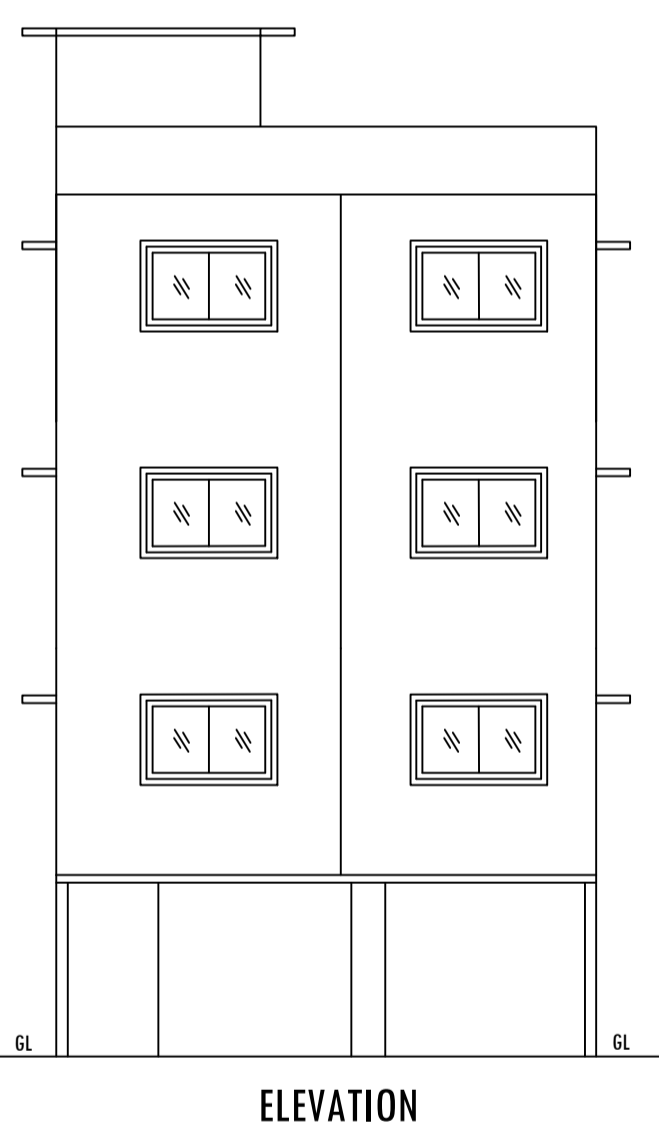

ELEVATION

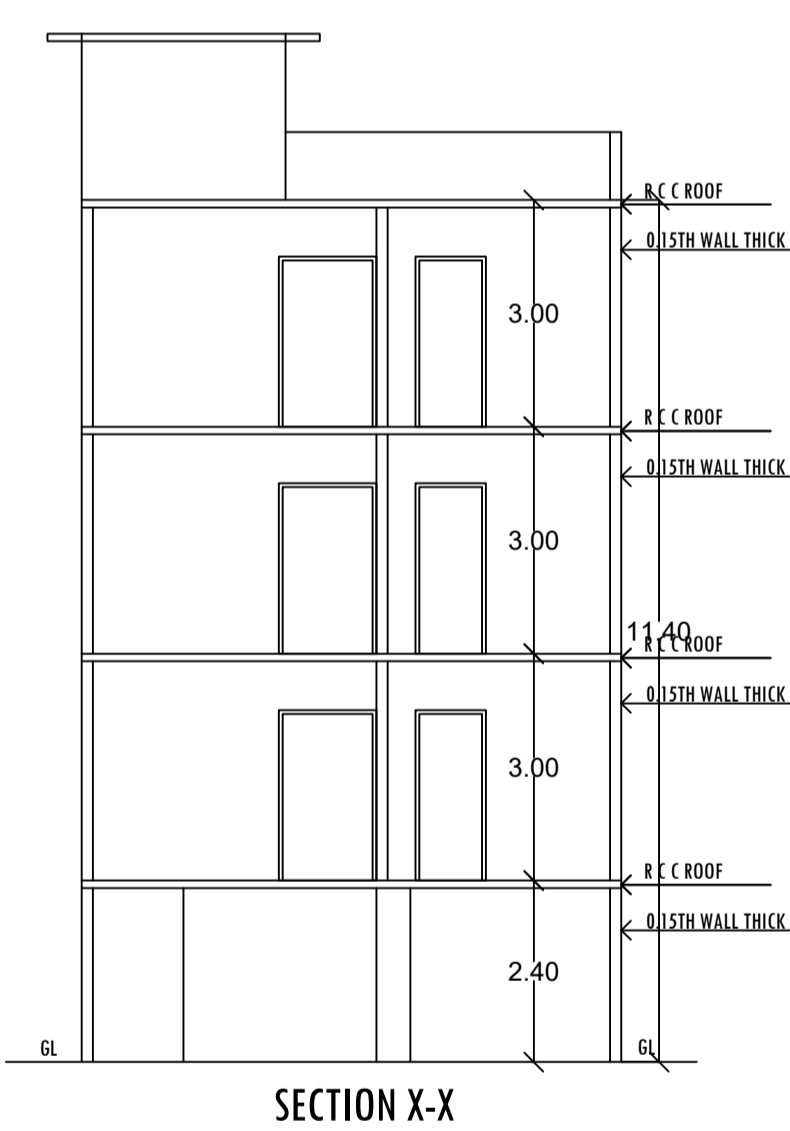

SECTION X-X

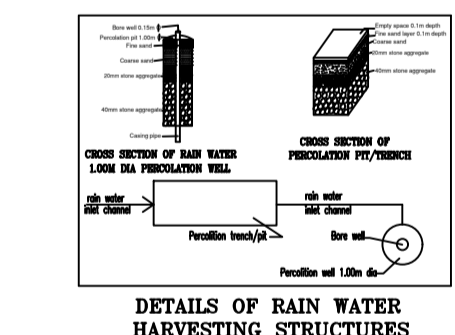

DETAILS OF RAIN WATER HARVESTING STRUCTURES

Approval Condition :
This Plan Sanction is issued subject to the following conditions :
1. The sanction is accorded for:
a) Consisting of Block -AA (BB) Wing -AA-1 (BB) Consisting of GF, STILT+2UF.
2. The sanction is accorded for Plotted Resi development AA (BB) only.
... 47. Debris or C&D waste generated while constructing the building should be taken to MS Rock Crystals NO.194 CHIKKAJALLA Bangalore- 562157

Table with columns: AREA STATEMENT (BBMP), PROJECT DETAIL, COVERAGE CHECK, FAR CHECK, BUILT UP AREA CHECK. Includes details like Plot Use: Residential, Area of Plot: 111.42, and various coverage percentages.

Approval Date : 09/21/2020 4:16:27 PM

Payment Details

Payment details table with columns: Sr No., Challan Number, Receipt Number, Amount (INR), Payment Mode, Transaction Number, Payment Date, Remark.

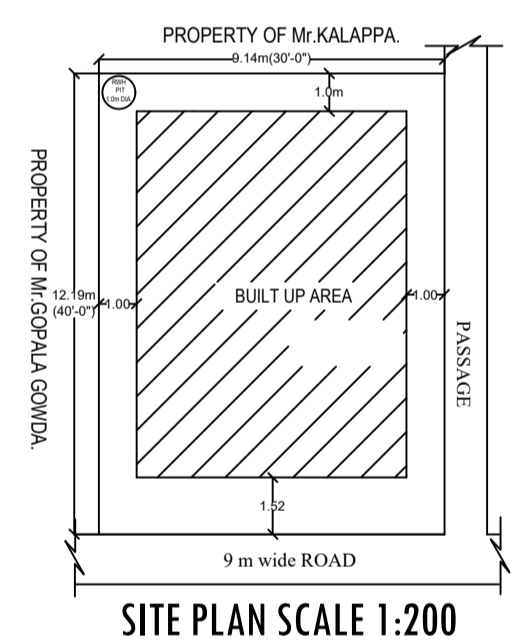

SITE PLAN SCALE 1:200

The plans are approved in accordance with the acceptance for approval by the Assistant Director of town planning (RR NAGAR) on date: 21/09/2020 vide lp number: BBMP/Ad.Corn./RJH/0678/20-21 subject to terms and conditions laid down along with this building plan approval.
This approval of Building plan / Modified plan is valid for two years from the date of issue of plan and building licence by the competent authority.
ASSISTANT DIRECTOR OF TOWN PLANNING (RR NAGAR)
BHRUHAT BENGALURU MAHANAGARA PALIKE

OWNER / GPA HOLDER'S SIGNATURE
OWNER'S ADDRESS WITH ID NUMBER & CONTACT NUMBER: Sri.K.RAVI. NO-21, TALGHATTAPURA VILLAGE, UTTARAHALLI HOBLI, BANGALORE SOUTH TALUK
ARCHITECT/ENGINEER /SUPERVISOR'S SIGNATURE MALLU MADHUSUDHAN REDDY #2, LEVEL 2, SB COMPLEX, NEXT TO IYER SCHOOL, HM MATHIKERE.
PROJECT TITLE: THE PLAN OF THE PROPOSED RESIDENTIAL BUILDING AT SITE NO-21, KATHA NO-83/21, TALGHATTAPURA VILLAGE, UTTARAHALLI HOBLI, BANGALORE SOUTH TALUK, WARD NO-198.
DRAWING TITLE: 864967465-26-08-2020 01-27-42\$, \$K RAVI 30X40 STG2 3 K :: AA (BB) WITH GF, STILT+2UF
SHEET NO: 1

Block USE/SUBUSE Details table with columns: Block Name, Block Use, Block SubUse, Block Structure, Block Land Use Category.

Required Parking (Table 7a) table with columns: Block Name, Type, SubUse, Area, Units, Car, Prop.

Parking Check (Table 7b) table with columns: Vehicle Type, No., Area, Achieved, Total.

FAR & Tenement Details table with columns: Block, No. of Same Bldg, Gross Built Up Area, Deductions, Total Built Up Area, Proposed FAR Area, Total FAR Area, Tnmt (No.).

Block :AA (BB) table with columns: Floor Name, Gross Builtup Area, Deductions, Total Built Up Area, Deductions (Area in Sq.mt), Proposed FAR Area, Total FAR Area, Tnmt (No.).

SCHEDULE OF JOINERY table with columns: BLOCK NAME, NAME, LENGTH, HEIGHT, NOS.

SCHEDULE OF JOINERY table with columns: BLOCK NAME, NAME, LENGTH, HEIGHT, NOS.

UnitBUA Table for Block :AA (BB) table with columns: FLOOR, Name, UnitBUA Type, UnitBUA Area, Carpet Area, No. of Rooms, No. of Tenement.